

По вопросам продаж и поддержки обращайтесь:

Архангельск (8182)63-90-72	Краснодар (861)203-40-90	Рязань (4912)46-61-64
Астана (7172)727-132	Красноярск (391)204-63-61	Самара (846)206-03-16
Белгород (4722)40-23-64	Курск (4712)77-13-04	Санкт-Петербург (812)309-46-40
Брянск (4832)59-03-52	Липецк (4742)52-20-81	Саратов (845)249-38-78
Владивосток (423)249-28-31	Магнитогорск (3519)55-03-13	Смоленск (4812)29-41-54
Волгоград (844)278-03-48	Москва (495)268-04-70	Сочи (862)225-72-31
Вологда (8172)26-41-59	Мурманск (8152)59-64-93	Ставрополь (8652)20-65-13
Воронеж (473)204-51-73	Набережные Челны (8552)20-53-41	Тверь (4822)63-31-35
Екатеринбург (343)384-55-89	Нижний Новгород (831)429-08-12	Томск (3822)98-41-53
Иваново (4932)77-34-06	Новокузнецк (3843)20-46-81	Тула (4872)74-02-29
Ижевск (3412)26-03-58	Новосибирск (383)227-86-73	Тюмень (3452)66-21-18
Казань (843)206-01-48	Орел (4862)44-53-42	Ульяновск (8422)24-23-59
Калининград (4012)72-03-81	Оренбург (3532)37-68-04	Уфа (347)229-48-12
Калуга (4842)92-23-67	Пенза (8412)22-31-16	Челябинск (351)202-03-61
Кемерово (3842)65-04-62	Пермь (342)205-81-47	Череповец (8202)49-02-64
Киров (8332)68-02-04	Ростов-на-Дону (863)308-18-15	Ярославль (4852)69-52-93

Единый адрес: edi@nt-rt.ru **Веб-сайт:** www.linde.nt-rt.ru

Взрывозащищенные электрические погрузчики E 14-20 Ex LINDE МН. Техническое описание



Electric Trucks for potentially hazardous areas Capacity 1400 – 2000 kg E 14 Ex – E 20 Ex

SERIES 386

Linde Material Handling

Linde

Explosion-Protected Trucks

The E 14 Ex up to E 20 Ex electric trucks for use in explosion-hazard areas are based on the standard truck model design-Series 386. These specialised trucks also incorporate the high performance and unique features of the standard high volume models:

Exemplary ergonomics, advanced technology, high stability, excellent economy and extended working life

The trucks comply with EG regulations for use in potentially explosive environments (EN 1755) and the ATEX version has been type-tested to Directive 94/4/EC by the „Institut National De L’environnement Industriel et des Risques“ (INERIS). **Type Examination Certificate: 07ATEX3004 X.**

Accordingly, these type-tested trucks, which have passed a gas penetration test, are approved for use in potentially hazardous areas as follows:

Zone 2 (3G), IIA or II B, temperature class to T4

Safety

AC drive motors, lift hydraulics and controls are gas-tight to comply with Ex-proof regulations.

The permanent working control unit is protected by a pressure-tight “d” casing to ensure its functionality and reliability.

Gates, relays and electrical buffers are protected by gas-tight steel modules.

All motors, brakes, oil-valves and controls are temperature monitored.

The multifunction display, hour meter and pressure-tight battery discharge indicator provide the trucks operating status.

Additionally, electrically conducting tyres and a non-sparking fork coating enhances the trucks safety levels for operation in potentially hazardous areas.

Technical data

Additional data and models in standard data sheets of series 386

Distinguishing mark	1.1	Manufacturer (abbreviation)		LINDE	LINDE
	1.2	Manufacturer's type designation		E 14 Ex	E 20 PL Ex
	1.3	Drive: electric (battery or mains), diesel, petrol, fuel gas		Battery	Battery
	1.4	Operator type: hand, pedestrian, standing, seated, order-picker		Seated	Seated
	1.5	Load capacity/rated load	Q (t)	1.4	2.0
	1.6	Load centre distance	c (mm)	500	500
	1.8	Load distance, centre of drive axle to for	x (mm)	365	374
	1.9	Wheelbase	y (mm)	1301 ¹⁾	1481 ¹⁾
Weight	2.1	Service weight	kg	2861	3516
	2.2	Axle loading, laden front/rear	kg	3758/503	4890/626
	2.3	Axle loading, unladen front/rear	kg	1427/1433	1710/1806
Tyres, chassis	3.1	Tyres: solid rubber, superelastic, pneumatic, polyurethane		SE	SE
	3.2	Tyre size, front		18 x 7 - 8 ²⁾	200/50 - 10 ⁵⁾
	3.3	Tyre size, rear		15 x 4 1/2 - 8 ³⁾	16 x 6 - 8 ³⁾
	3.5	Wheels, number front rear (x = driven wheels)		2x/2	2x/2
	3.6	Tread, front	b10 (mm)	930	965
	3.7	Tread, rear	b11 (mm)	168	807
	Dimensions	4.1	Tilt of mast/fork carriage forward/backward	a/b (°)	5/7.5
4.2		Height, mast lowered	h1 (mm)	2194 ⁴⁾	2194 ⁴⁾
4.3		Free lift	h2 (mm)	150	150
4.4		Lift	h3 (mm)	3110	3110
4.5		Height, mast extended	h4 (mm)	3713	3713
4.7		Height of overhead guard (cabin)	h6 (mm)	1970	2130
4.8		Seat height/stand height	h7 (mm)	908	1065
4.12		Coupling height	h10 (mm)	510	602
4.19		Overall length	l1 (mm)	2746	2987
4.20		Length to face of forks	l2 (mm)	1846	2087
4.21		Overall width	b1/b2 (mm)	1090/1050 ⁷⁾	1172/1050 ⁷⁾
4.22		Fork dimensions	s/e/l (mm)	40 x 80 x 900	40 x 80 x 1000
4.23		Fork carriage DIN 15 173, class/type A, B		2A	2A
4.24		Fork-carriage width	b3 (mm)	1040	1040
4.31		Ground clearance, laden, below mast	m1 (mm)	89	97
4.32		Ground clearance, centre of wheelbase	m2 (mm)	96	103
4.33		Aisle width for pallets 1000 x 1200 crossways	Ast (mm)	3177	3412
4.34		Aisle width for pallets 800 x 1200 lengthways	Ast (mm)	3301	3537
4.35		Turning radius	Wa (mm)	1486	1713
4.36		Internal turning radius	b13 (mm)	-	-
Performance data	5.1	Travel speed, laden/unladen	km/h	16/16	20/20
	5.2	Lift speed, laden/unladen	m/s	0.4/0.6	0.5/0.5
	5.3	Lowering speed, laden/unladen	m/s	0.58/0.47	0.58/0.47
	5.5	Drawbar pull, laden/unladen	N	2300/2300	2300/2300
	5.6	Max. drawbar pull, laden/unladen	N	9200/9200	10000/10000
	5.7	Gradeability, laden/unladen	%	7.3/11.0	5.7/8.9
	5.8	Max. gradeability, laden/unladen	%	22.6/34.7	18.8/30.3
	5.9	Acceleration time, laden/unladen	s	4.5/4.0	4.6/4.0
	5.10	Service brake		hydr./mech.	hydr./mech.
	Electric-engine	6.1	Drive motor rating S2 60 min	kW	2 x 4.6
6.2		Lift motor rating at S3 15 %	kW	10	11
6.3		Battery acc. to DIN 43 531/35/36 A, B, C, no		43531A	43531A
6.4		Battery voltage, nominal capacity K5	V/Ah	48/440(460) ⁹⁾	48/700 (700) ⁹⁾
6.5		Battery weight	kg	708	1118
6.6		Energy consumption acc. to VDI cycle	kW/h	6.2	7.6
Addition data	8.1	Traction control		digital/ininitely variable	digital/ininitely variable
	8.2	Operating pressure for attachments	bar	180	170
	8.3	Oil volume for attachments	l/min	32 ⁸⁾	32 ⁸⁾
	8.4	Sound level at the driver's ear according to DIN 12 053	dB (A)	<65	<65
	8.5	Towing coupling, type DIN		-	-
<p>1) With lifting mast vertical 2) Optional: pneumatic tyres, 18 x 7 - 8 7 16 PR or wrap-around 3) Optional: pneumatic tyres, 15 x 4 1/2 - 8/12PR 4) Optional: pneumatic tyres, 16 x 6 - 8/10PR 5) Optional: wrap-around tyres 6) With 150 mm free lift 7) With wrap-around tyre, 18 x 6 b1 - 1074 8) At 80 % nominal pressure (8.2) 9) Data between brackets are taken from the instruction leaflet on "Use of European-series DIN-standard batteries" (July 2002 edition).</p>					

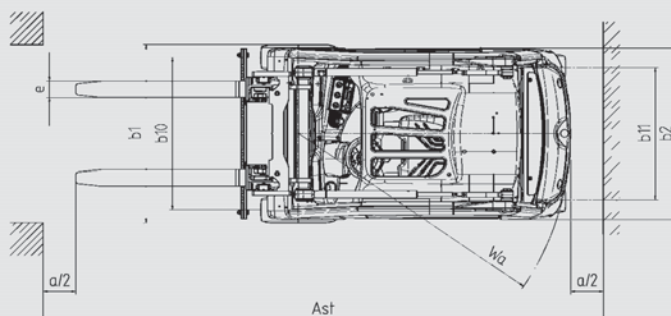
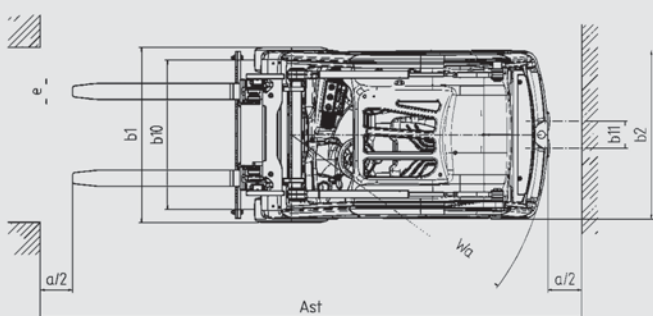
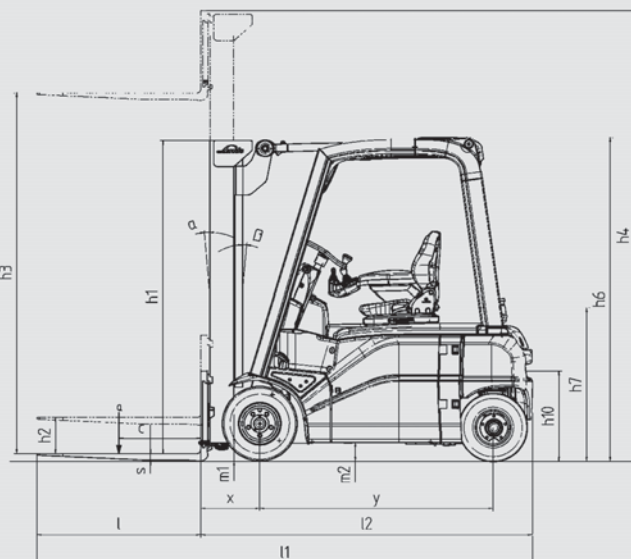
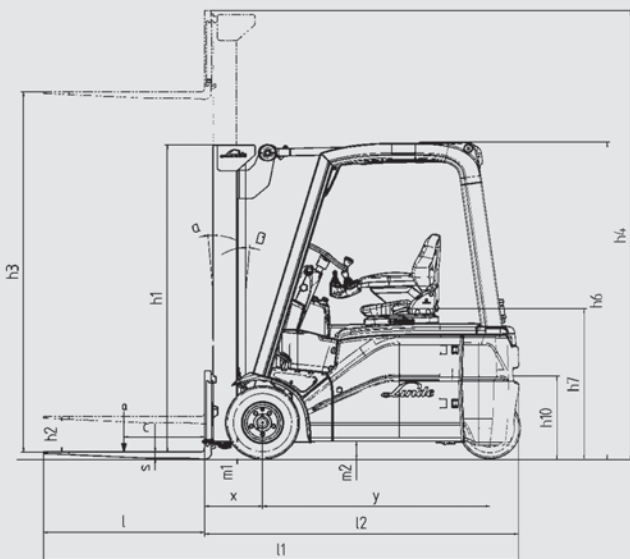

Lifting capacity diagrams in standard data sheets of series 386

All Ex-components are protected and undergo a gas-infiltration-test, which is demanded by EN 1755 as well for vehicles with Gas safety systems.

This ensures the highest safety levels for the operator.

The monitoring system consisting of sensor and control unit is operating continuously and ensures a constant availability.

The sensor measures gas concentration in ambient air.

The control unit records data and will raise an audible signal, if there is 10% gas concentration in ambient air. The operator has to acknowledge the warning.

After exceeding the upper limit of 25% gas concentration, the truck cuts off.

Following acknowledgement and after the gas concentration falls below the upper limit, the operator can immediately

continue working. Re-calibration of the system is not necessary. All permanently energised electrical components are protected in gas-tight modules.

The electrical back up control remains functional for up to 120 minutes in the event of a power interruption (battery change).

A battery connection ensures that the control unit remains energised during battery charging.

The temperature monitoring of drive, steering and lift motors, brakes and control module provides additional safety.

Calibration of the Linde Gas safety system is only necessary every three months/quarterly (see manual).



Gas sensor



Control unit



Calibration set

Features

Linde clearview mast design

- with top mounted tilt cylinders → Excellent view of load and surroundings through the robust yet slim mast profiles
- Nominal capacity retained to maximum lift heights
- High residual capacities in all applications
- Exceptionally stable

Forks

- Brass coated to prevent sparking



Linde hydrostatic power steering

- Progressive steering torque
- Minimal physical demands on the operator
- Compact ergonomically designed steering wheel
- Linde close coupled steer axle for outstanding maneuverability

Gas safety system

- Sensor atop overhead guard
- Sensor at ground level in counterbalance

Linde twin drive pedal

- Seamless, rapid reversing without repositioning the feet
- Short pedal travel
- Fatigue-free working
- Increased throughput and performance

Linde Load Control

- Safe and seamless load handling with millimetre accuracy
- Effortless fingertip control of all mast functions
- Joystick controls integrated into the armrest

Economical AC drive

- Two powerful AC drive motors integrated in the front axle
- Seamless acceleration and variable torque characteristics
- Excellent structural integrity and stability
- Extremely quiet in operation



Linde operator compartment

- Ergonomically designed for efficient, fatigue-free working
- Spacious operator's compartment with generous floor plate area
- Cushioned comfort – mast and drive axle are isolated from the chassis and cab by a unique resilient suspension system that absorbs shock loadings
- Acknowledgement-button for GS-system

Linde compact drive axle

- Twin drive design with high performance Linde AC technology
- Integrate lift motor
- Optimum energy efficiency
- Maintenance-free oil-bath vane brake
- Electronic components housed in sealed unit for complete protection
- Special protection and temperature monitoring for use in Ex-areas

Linde energy management

- Optimised energy consumption
- Accurate battery condition indicator
- Simple horizontal or vertical battery changing options
- Controls and components tuned to the Ex-environment

Ex-Battery

- Ex-tested battery cells, battery cover and additional connections for monitoring unit

Subject to modification in the interests of engineering progress. Illustrations and technical details non-binding for actual construction. All measurements subject to customary tolerances.

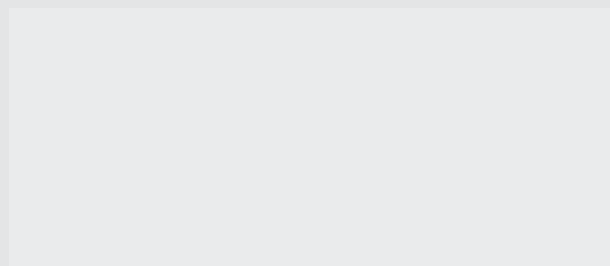

Linde Material Handling

По вопросам продаж и поддержки обращайтесь:

Архангельск (8182)63-90-72	Краснодар (861)203-40-90	Рязань (4912)46-61-64
Астана (7172)727-132	Красноярск (391)204-63-61	Самара (846)206-03-16
Белгород (4722)40-23-64	Курск (4712)77-13-04	Санкт-Петербург (812)309-46-40
Брянск (4832)59-03-52	Липецк (4742)52-20-81	Саратов (845)249-38-78
Владивосток (423)249-28-31	Магнитогорск (3519)55-03-13	Смоленск (4812)29-41-54
Волгоград (844)278-03-48	Москва (495)268-04-70	Сочи (862)225-72-31
Вологда (8172)26-41-59	Мурманск (8152)59-64-93	Ставрополь (8652)20-65-13
Воронеж (473)204-51-73	Набережные Челны (8552)20-53-41	Тверь (4822)63-31-35
Екатеринбург (343)384-55-89	Нижний Новгород (831)429-08-12	Томск (3822)98-41-53
Иваново (4932)77-34-06	Новокузнецк (3843)20-46-81	Тула (4872)74-02-29
Ижевск (3412)26-03-58	Новосибирск (383)227-86-73	Тюмень (3452)66-21-18
Казань (843)206-01-48	Орел (4862)44-53-42	Ульяновск (8422)24-23-59
Калининград (4012)72-03-81	Оренбург (3532)37-68-04	Уфа (347)229-48-12
Калуга (4842)92-23-67	Пенза (8412)22-31-16	Челябинск (351)202-03-61
Кемерово (3842)65-04-62	Пермь (342)205-81-47	Череповец (8202)49-02-64
Киров (8332)68-02-04	Ростов-на-Дону (863)308-18-15	Ярославль (4852)69-52-93

Единый адрес: edi@nt-rt.ru **Веб-сайт:** www.linde.nt-rt.ru