

По вопросам продаж и поддержки обращайтесь:

Архангельск (8182)63-90-72	Краснодар (861)203-40-90	Рязань (4912)46-61-64
Астана (7172)727-132	Красноярск (391)204-63-61	Самара (846)206-03-16
Белгород (4722)40-23-64	Курск (4712)77-13-04	Санкт-Петербург (812)309-46-40
Брянск (4832)59-03-52	Липецк (4742)52-20-81	Саратов (845)249-38-78
Владивосток (423)249-28-31	Магнитогорск (3519)55-03-13	Смоленск (4812)29-41-54
Волгоград (844)278-03-48	Москва (495)268-04-70	Сочи (862)225-72-31
Вологда (8172)26-41-59	Мурманск (8152)59-64-93	Ставрополь (8652)20-65-13
Воронеж (473)204-51-73	Набережные Челны (8552)20-53-41	Тверь (4822)63-31-35
Екатеринбург (343)384-55-89	Нижний Новгород (831)429-08-12	Томск (3822)98-41-53
Иваново (4932)77-34-06	Новокузнецк (3843)20-46-81	Тула (4872)74-02-29
Ижевск (3412)26-03-58	Новосибирск (383)227-86-73	Тюмень (3452)66-21-18
Казань (843)206-01-48	Орел (4862)44-53-42	Ульяновск (8422)24-23-59
Калининград (4012)72-03-81	Оренбург (3532)37-68-04	Уфа (347)229-48-12
Калуга (4842)92-23-67	Пенза (8412)22-31-16	Челябинск (351)202-03-61
Кемерово (3842)65-04-62	Пермь (342)205-81-47	Череповец (8202)49-02-64
Киров (8332)68-02-04	Ростов-на-Дону (863)308-18-15	Ярославль (4852)69-52-93

Единый адрес: edi@nt-rt.ru **Веб-сайт:** www.linde.nt-rt.ru

Комплектовщики заказов N 20 Vi/Vli LINDE MH. Техническое описание



Low-Level Man-up Order Pickers Capacity 2000 kg N20Vi, N20VLi

SERIES 1111

Safety

At the edge of the platform the operator has a perfect grip thanks to a slightly inclined edge for a safe pick. While lifting/lowering the fork carriage on the N20VLi, the operator is protected from the mast by a polycarbonate window. At no time operator's body exposed beyond the contours of the truck.

Performance

Models N20Vi and N20VLi are designed to optimize occasional 1st and 2nd level order picking with 2 different methods of putting down a picked item on forks. As the proportion of items to be picked at height is small, only the platform rises for faster picking cycle. The OptiLift proportional control rises and lowers platform for accurate picking. Lowering of platform can also be controlled by an easy to use foot switch.

Comfort

Low 135 mm step-in height and wide 432 mm entry on both sides allow easy and frequent access to the order pickers. For more comfort, the damped platform mat is acting as a deadman sensor. The user-friendly twin-grip control concentrates all controls within easy reach of either hand. While lowering, soft landing of the platform brings further comfort to the operator.

Reliability

Linde offers 2 versions of order pickers for occasional 1st and 2nd picking level to provide the optimum solution for individual organisation. The central drive wheel guarantees traction as well as straight drive down the aisle and a perfect braking. In addition, the fork tips (N20Vi) which each withstands 2000 kg contribute to a long, trouble-free life.

Service

Speed and economy continue over into truck diagnosis and preventive maintenance. The digital multifunction instrument display ensures the operator is always well informed. CAN-bus connectivity enables all truck data to be transmitted to a laptop by the service technician. Easy accessibility of all components and maintenance-free AC technology also play an important role in maximising truck uptime.

Linde Material Handling

Linde

Technical Data (According to VDI 2198)

Characteristics	1.1	Manufacturer	
	1.2	Model designation	
	1.3	Power unit	
	1.4	Operation	
	1.5	Load capacity	Q (t)
	1.6	Load centre	c (mm)
	1.8	Axle centre to fork face	x (mm)
	1.9	Wheelbase	y (mm)
	Weights	2.1	Service weight
2.2		Axle load with load, front/rear	(kg)
2.3		Axle load without load, front/rear	(kg)
Wheels/Tyres	3.1	Tyres	
	3.2	Tyre size, front	
	3.3	Tyre size, rear	
	3.5	Wheels, number front/rear (x = driven)	
	3.6	Track width, front	b10 (mm)
	3.7	Track width, rear	b11 (mm)
	Dimensions	4.2	Height of mast, lowered
4.4		Lift	h3 (mm)
4.5		Height of mast, extended	h4 (mm)
4.6		Initial lift	h5 (mm)
4.8		Height of seat/stand-on platform	h7 (mm)
4.9		Height of tiller arm in operating position, min/max	h14 (mm)
4.14		Platform height, raised	h12 (mm)
4.15		fork height, lowered	h13 (mm)
4.19		Overall length	l1 (mm)
4.20		Length to fork face	l2 (mm)
4.21		Overall width	b1/b2 (mm)
4.22		Fork dimensions	s/e/l (mm)
4.23		Fork carriage to ISO 2328, class/type A, B	
4.25		Fork spread, min/max	b5 (mm)
4.26		Width between reach legs	b4 (mm)
4.32		Ground clearance, centre of wheelbase	m2 (mm)
4.34		Aisle width with pallet 800 x 1200 along forks	Ast (mm)
4.35	Turning radius	Wa (mm)	
Performance	5.1	Travel speed, with/without load	(km/h)
	5.2	Lifting speed, with/without load	(m/s)
	5.3	Lowering speed, with/without load	(m/s)
	5.8	Maximum climbing ability, with/without load	(%)
	5.10	Service brake	
Drive	6.1	Drive motor, 60 minute rating	(kW)
	6.2	Lift motor rating at S3 15%	(kW)
	6.3	Battery according to DIN 43531/35/36 A,B,C,no	
	6.4	Battery voltage/rated capacity (5h)	(V/Ah)
	6.5	Battery weight (± 5%)	(kg)
	6.6	Power consumption according to VDI cycle	(kWh/h)
Others	8.1	Type of drive control	
	8.4	Noise level at operator's ear	(dB(A))
1) (± 5 mm) 2) ± 0 mm = 3 PzS; +100 mm = 4 PzS 3) Overhang 188 mm 4) (± 10%)		5) Figures with battery, see line 6.4/6.5. 6) (± 5%) 7) (Platform);(forks) 8) (Platform);(initial lift);(forks)	

LINDE	LINDE
N 20 VI	N 20 VLi
Battery	Battery
Order Picker	Order Picker
2.0	2.0
600	600
962 ¹⁾	723 ¹⁾
2289 ²⁾³⁾¹⁾	2239 ²⁾¹⁾
1377.0 ⁴⁾⁵⁾	1781.0 ⁴⁾⁵⁾
1327.0/2050.0 ⁴⁾⁵⁾	1276.0/2505.0 ⁴⁾⁵⁾
1011.0/366.0 ⁴⁾⁵⁾	1166.0/615.0 ⁴⁾⁵⁾
Polyurethane	Polyurethane
254X102	254X102
4xØ85x80	4xØ85x60
1x +2 / 4	1x +2 / 4
277 / 277 ¹⁾	277 / 277 ¹⁾
355/395 ¹⁾	380 ¹⁾
1292 ¹⁾	1500 ¹⁾
1065 ¹⁾	1065 ¹⁾
2357 ¹⁾	2357 ¹⁾
110	110
135	135
1244	1244
1200 ¹⁾	1200 ¹⁾
86	86
2667 ²⁾³⁾¹⁾	2855 ²⁾¹⁾
1517 ²⁾³⁾¹⁾	1705 ²⁾¹⁾
800 ¹⁾	800 ¹⁾
60x165x1150	60x182x1150
no	no
520/560 ¹⁾	560 ¹⁾
246 / 286	230
30	30
2929	2950
2491	2470
10.0/10.0 ⁴⁾	10.0/10.0 ⁴⁾
(0.21/0.21);(0.065/0.117) ⁴⁾⁷⁾	(0.21/0.21);(0.07/0.12);(0.16/0.24) ⁴⁾⁸⁾
(0.5/0.5);(0.068/0.068) ⁴⁾⁷⁾	(0.4/0.4);(0.08/0.08);(0.4/0.15) ⁴⁾⁸⁾
11/15	11/15
Electric/hydraulic	Electric/hydraulic
3.0	3.0
3.0	3.0
43 535	43 535
24/375	24/375
220	220
0,71	0,71
LAC	LAC
74	74

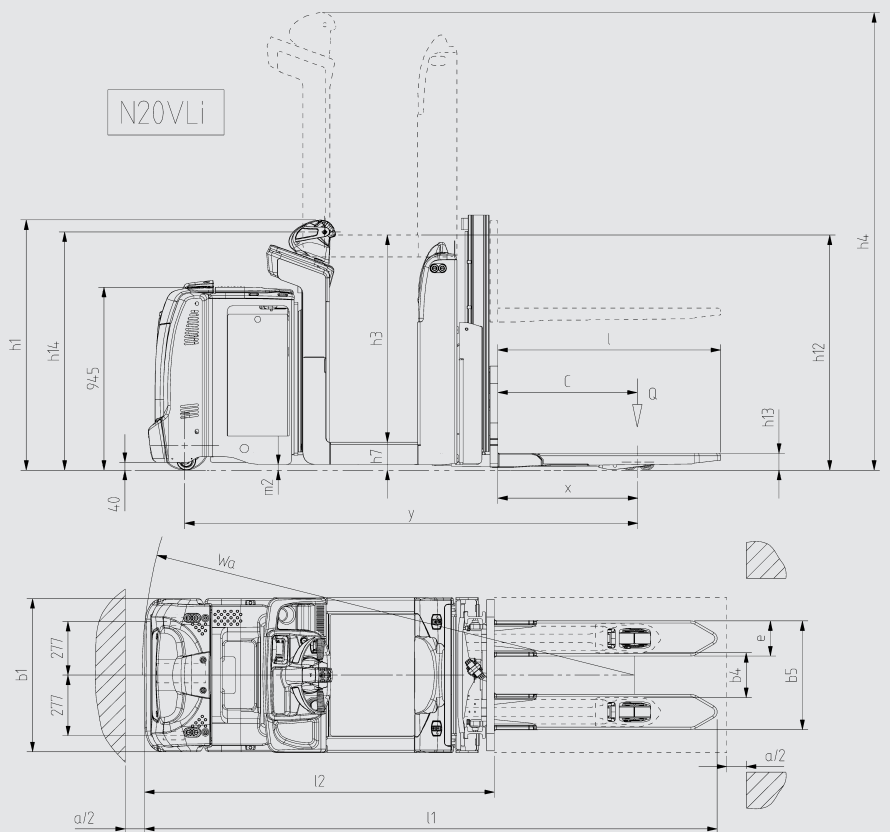
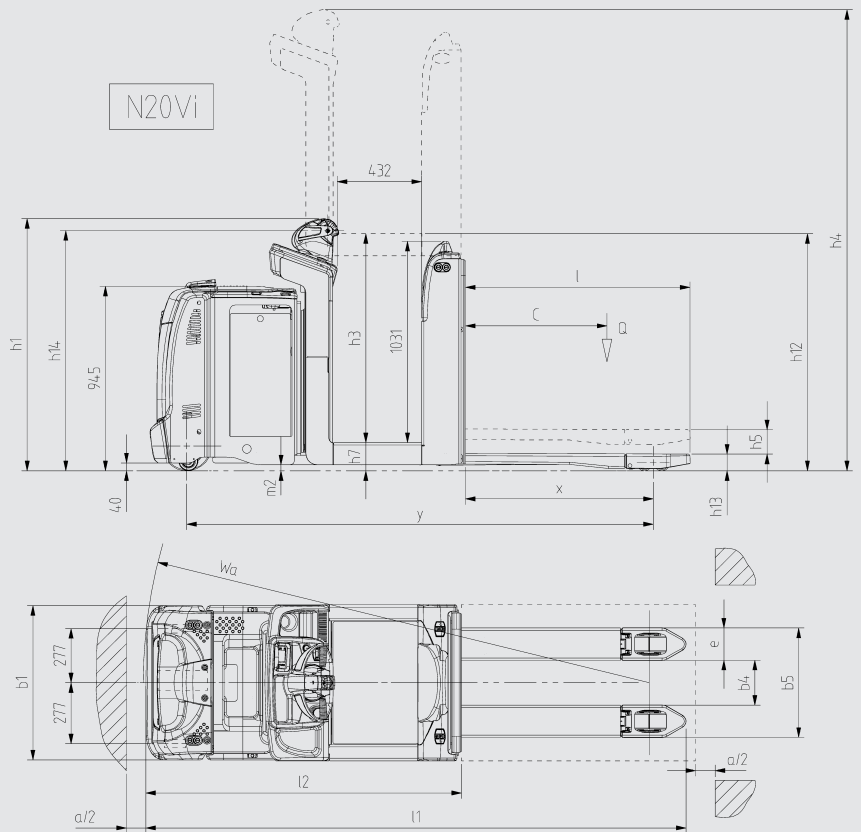



Standard Equipment/Optional Equipment

Standard Equipment

Backlit multifunction display with hourmeter, maintenance indication, battery discharge indicator and internal fault code

Truck activated by entering PIN-code or by ignition key

Safe operator compartment with cushioned mat

Workstation incorporating various storage compartments

Power-assisted steering, adjustable steering resistance

Self-centering steering

Automatic speed reduction on turns

OptiLift® system for rising platform and fork carriage (N20VLi)

AC drive motor

Automatic braking on releasing butterfly switch

Electromagnetic emergency brake acting proportionally to the load weight

CAN-bus architecture

Cushion rubber drive wheel

Tandem polyurethane load wheels

Side battery change on rollers 3 PzS or 4 PzS

Different forks length available from 1150 to 2350 mm (N20Vi)

560 mm fork carriage width (N20VLi)

Standard Mast: 750/1320/750 mm (N20VLi)

Electric horn

Low temperature protection to -10°C

Optional Equipment

Drive wheel: polyurethane, cushion non-marking or wet grip

Tandem polyurethane load wheels greasable

Inching buttons

Rotating clipboard

Support for data terminal on a front bow

Front shelf (50kg capacity)

Picking pack: Rotating clipboard with front shelf

Truck activated by biometry with possibility to parameter each driver access - safest truck access monitoring

Speed reduction when initial lift lowered

Fixed battery stand for side battery change

3 meter extension battery cable

Cold store protection -35°C

Other options available on request

Features

Two versions are available

- Compact chassis width of 800 mm
- Model N20Vi, order picker with initial lift and rising platform
- Model N20VLi, order picker with initial lift, rising platform and additional mast. OptiLift® system for ergonomic lay at operator's height

Rising platform

- Wide access of 432 mm and low step-in height (135 mm)
- OptiLift® system to lift the platform provides fully proportional lifting as well as quiet operation
- Lowering can be controlled by a foot switch
- Soft landing of the forks protects load when lowering



Workstation

- Numerous storage compartments all around the controls and operator to store picking tools
- Battery cover's design offers shrink wrapped paper holder and further storage area
- Various optional accessories designed to streamline picking, including large workshelf



Linde multifunction display

- Digital multifunction display as standard with hourmeter, maintenance indication, battery discharge indicator, fault code indication
- Truck activated by PIN-code, ignition key or by the innovative biometrical access (optional)



Energy

- Battery range available from 375 Ah up to 500 Ah
- Safe and easy side battery change (left or right) mounted on rollers
- Linde locking system secures battery in compartment and eases side change
- Direct access to release the battery from the locking system without rising the platform



Drive system

- Powerful, smooth-running AC motor, 3 kW (at 100% output)
- Traction speed adjustable up to 10 km/h, laden or unladen and 5 km/h with the platform is up
- Automatic braking on releasing the travel switch
- Electromagnetic braking initiated by the emergency stop button acts on the drive motor, proportional to the load carried

Power steering & Linde control twin-grip

- Proportional power-assisted steering, self-centering and effortless to operate
- Positive steering feedback results in an efficient stability
- Automatic speed reduction when cornering
- All controls can be accessible by either right or left hand
- Simultaneous driving/lifting action enables fast move in-between two picks

CAN-bus connectivity/Service

- All truck parameters can be configured by the service technician to achieve best performance in every application
- Electronic management of all components permitting quick and easy diagnosis
- Rapid and convenient access to main components via front service panel
- Moisture and dust-proof motor, with zero maintenance requirement

Subject to modification in the interests of progress. Illustrations and technical details not binding for actual constructions. All dimensions subject to usual tolerances.

По вопросам продаж и поддержки обращайтесь:

Архангельск (8182)63-90-72	Краснодар (861)203-40-90	Рязань (4912)46-61-64
Астана (7172)727-132	Красноярск (391)204-63-61	Самара (846)206-03-16
Белгород (4722)40-23-64	Курск (4712)77-13-04	Санкт-Петербург (812)309-46-40
Брянск (4832)59-03-52	Липецк (4742)52-20-81	Саратов (845)249-38-78
Владивосток (423)249-28-31	Магнитогорск (3519)55-03-13	Смоленск (4812)29-41-54
Волгоград (844)278-03-48	Москва (495)268-04-70	Сочи (862)225-72-31
Вологда (8172)26-41-59	Мурманск (8152)59-64-93	Ставрополь (8652)20-65-13
Воронеж (473)204-51-73	Набережные Челны (8552)20-53-41	Тверь (4822)63-31-35
Екатеринбург (343)384-55-89	Нижний Новгород (831)429-08-12	Томск (3822)98-41-53
Иваново (4932)77-34-06	Новокузнецк (3843)20-46-81	Тула (4872)74-02-29
Ижевск (3412)26-03-58	Новосибирск (383)227-86-73	Тюмень (3452)66-21-18
Казань (843)206-01-48	Орел (4862)44-53-42	Ульяновск (8422)24-23-59
Калининград (4012)72-03-81	Оренбург (3532)37-68-04	Уфа (347)229-48-12
Калуга (4842)92-23-67	Пенза (8412)22-31-16	Челябинск (351)202-03-61
Кемерово (3842)65-04-62	Пермь (342)205-81-47	Череповец (8202)49-02-64
Киров (8332)68-02-04	Ростов-на-Дону (863)308-18-15	Ярославль (4852)69-52-93

Единый адрес: edi@nt-rt.ru **Веб-сайт:** www.linde.nt-rt.ru