

По вопросам продаж и поддержки обращайтесь:

Архангельск (8182)63-90-72	Краснодар (861)203-40-90	Рязань (4912)46-61-64
Астана (7172)727-132	Красноярск (391)204-63-61	Самара (846)206-03-16
Белгород (4722)40-23-64	Курск (4712)77-13-04	Санкт-Петербург (812)309-46-40
Брянск (4832)59-03-52	Липецк (4742)52-20-81	Саратов (845)249-38-78
Владивосток (423)249-28-31	Магнитогорск (3519)55-03-13	Смоленск (4812)29-41-54
Волгоград (844)278-03-48	Москва (495)268-04-70	Сочи (862)225-72-31
Вологда (8172)26-41-59	Мурманск (8152)59-64-93	Ставрополь (8652)20-65-13
Воронеж (473)204-51-73	Набережные Челны (8552)20-53-41	Тверь (4822)63-31-35
Екатеринбург (343)384-55-89	Нижний Новгород (831)429-08-12	Томск (3822)98-41-53
Иваново (4932)77-34-06	Новокузнецк (3843)20-46-81	Тула (4872)74-02-29
Ижевск (3412)26-03-58	Новосибирск (383)227-86-73	Тюмень (3452)66-21-18
Казань (843)206-01-48	Орел (4862)44-53-42	Ульяновск (8422)24-23-59
Калининград (4012)72-03-81	Оренбург (3532)37-68-04	Уфа (347)229-48-12
Калуга (4842)92-23-67	Пенза (8412)22-31-16	Челябинск (351)202-03-61
Кемерово (3842)65-04-62	Пермь (342)205-81-47	Череповец (8202)49-02-64
Киров (8332)68-02-04	Ростов-на-Дону (863)308-18-15	Ярославль (4852)69-52-93

Единый адрес: edi@nt-rt.ru **Веб-сайт:** www.linde.nt-rt.ru

Тягачи P20/W04 LINDE МН. Техническое описание

Standard Equipment/Optional Equipment

Standard Equipment

Three wheel configuration	1.5 kW AC drive motor
Cushion rubber drive and load wheels non marking	Hook three positions
Castor wheels	Multi-function display with indication of hour meter, battery discharge, maintenance visit and trouble code
Vertical and lateral battery change 2 PzB 200Ah	Horn
Foldable and height adjustable seat	Automatic parking brake
Height adjustable handle bar	Emergency stop
Backrest	Deadman foot switch
Position light LED front and rear	Digital LAC controller
Towing attachment control on both chassis sides	External access to CAN Bus plug
Generous storage compartments	Protection to -10°C
Metal clip on battery cover	
Key switch	

Optional Equipment

Truck lighting (position light, working light, turning indicators)	Built-in charger
Various towing couplings	Accessory bar
Knee protection	Mirrors left and right
Platform for load transporter	PIN code access
Higher ground clearance for outdoor application	



Tractor P 20
Capacity 2000 kg
Load Transporter W 04
Capacity 400 kg

Series 1193

Safety

The chassis design assures that the operator remains well protected within the truck contours while driving. The ergonomic twin grip steering control incorporates a wrap-around hand guard. For additional safety tractor and load transporter are available with knee protection.

Performance

With only 600 mm width and its high manoeuvrability it is perfectly suited for towing applications in narrow aisles. The maintenance-free 1.5 kW drive motor assures smooth and powerful acceleration for loads up to 2000 kg.

Comfort

A foldable and height adjustable seat offers the operator more comfort while driving long distances. A higher ground clearance is available for indoor/outdoor application.

Reliability

The robustness of steering control and high quality steel chassis ensure reliable operation. Optional lights are recessed in cover. High durable electronic components also contribute to increased truck life.

Serviceability

Efficient in operation and highly cost effective. External CAN bus plug enables all truck data to be accessed for service inspection without removing any cover. Easy accessibility to all components and the use of maintenance free AC motors contribute to fast service times.

Features

Chassis

- Only 600 mm width
- Lights are recessed inside cover
- Robust chassis of rugged steel
- All plastic components are well protected within chassis contours
- Ergonomic and safe rounded profile design



Steering

- Precise, direct and responsive steering
- Wide handle bar reduces steering effort
- Maximum manoeuvrability due to turning radius <1,100 mm
- Height adjustable handle bar

Operator's compartment

- Low step-in height
- Knee protection
- Backrest with side support
- Foldable and height adjustable seat
- Generous storage compartments on battery cover and below seat

Flexibility

- Loading platform for transporter version
- Higher ground clearance for outdoor application

Service

- Easy service access to all key components
- External diagnosis access to CAN Bus
- Driving parameters can be adjusted individually
- Maintenance-free, moisture and dust-proof 1.5 kW AC motor (IP 44)



Braking

- Automatic parking brake
- Emergency stop
- Automatic electric braking on releasing traction butterfly or reversing direction



Towing couplings

- Towing attachment control for easy coupling and decoupling
- Coupling is always in excellent view of operator
- Manual wire guided hook can be operated without leaving operator's platform
- Additional various coupling devices



Batteries and charger

- Quick and easy battery locking system
- 2 PzS-B 200 Ah battery
- Built-in charger
- Vertical and lateral battery change in one chassis

Subject to modification in the interest of progress. Illustrations and technical details could include options and not binding for actual constructions. All dimensions subject to usual tolerances.

Linde Material Handling

Linde



Technical Data according to VDI 2198

Characteristics	1.1	Manufacturer	LINDE	LINDE	
	1.2	Model designation	P20	W04	
	1.2a	Series	1193-00	1193-00	
	1.3	Power unit	Battery	Battery	
	1.4	Operation	Seat	Seat	
Weights	1.5	Load capacity/Load	Q (t)	2.0	0.4 / 1.0 ¹⁾
	1.7	Rated tractive force	F (N)	400	300
Wheels/Tyres	1.9	Wheelbase	y (mm)	907 ²⁾	1487 ²⁾
	2.1	Service weight	(kg)	630 ³⁾	730 ³⁾
	2.3	Axle load without load, front/rear	(kg)	350 / 280	460 / 270
	3.1	Tyres rubber, SE, pneumatic, polyurethane		C+PU/C	C+PU/C
	3.2	Tyre size, front		Ø 230 x 75	Ø 230 x 75
	3.3	Tyre size, rear		2 x Ø 250 x 80	2 x Ø 250 x 80
	3.5	Wheels, number front/rear (x = driven)		1x + 2 / 2	1x + 2 / 2
Dimensions	3.6	Track width, front	b10 (mm)	418 ²⁾	418 ²⁾
	3.7	Track width, rear	b11 (mm)	480	505
	4.8	Height of seat/stand on platform	h7 (mm)	800 / 985	840 / 1025
	4.9	Height of tiller arm in operating position, min/max	h14 (mm)	1170 / 1270	1210 / 1310
	4.12	Towing coupling height	h10 (mm)	276	165
	4.17	Rear overhang	l5 (mm)	253	531
	4.19	Overall length	l1 (mm)	1315	2172
	4.21	Overall width	b1/b2 (mm)	600 ²⁾	600 / 636 ²⁾
	4.32	Ground clearance, centre of wheelbase	m2 (mm)	40 / 80	80
	4.35	Turning radius	Wa (mm)	1080	1660
Performance	5.1	Travel speed, with/without load	(km/h)	8 / 8	8 / 8
	5.5	Tractive force, with/without load	(N)	400	300
	5.6	Maximum tractive force, with/without load	(N)	1760	1760
	5.7	Climbing ability, with/without load	(%)	-	-
	5.8	Maximum climbing ability, with/without load	(%)	5.0 / 10.0	5.0 / 10.0
Drive	5.10	Service brake		Electro-magnetic	Electro-magnetic
	6.1	Drive motor, 60 minute rating	(kW)	1.5	1.5
	6.3	Battery according to DIN 43531/35/36 A,B,C,no		2PzS-B	2PzS-B
	6.4	Battery voltage/rated capacity (5h)	(V/Ah)	24 / 200	24 / 200
	6.5	Battery weight (± 5%)	(kg)	185	185
	8.1	Type of drive control		LAC	LAC

1) on platform / + on the hook
2) (+ 5 mm)

3) Figures with battery, see line 6.4/6.5.

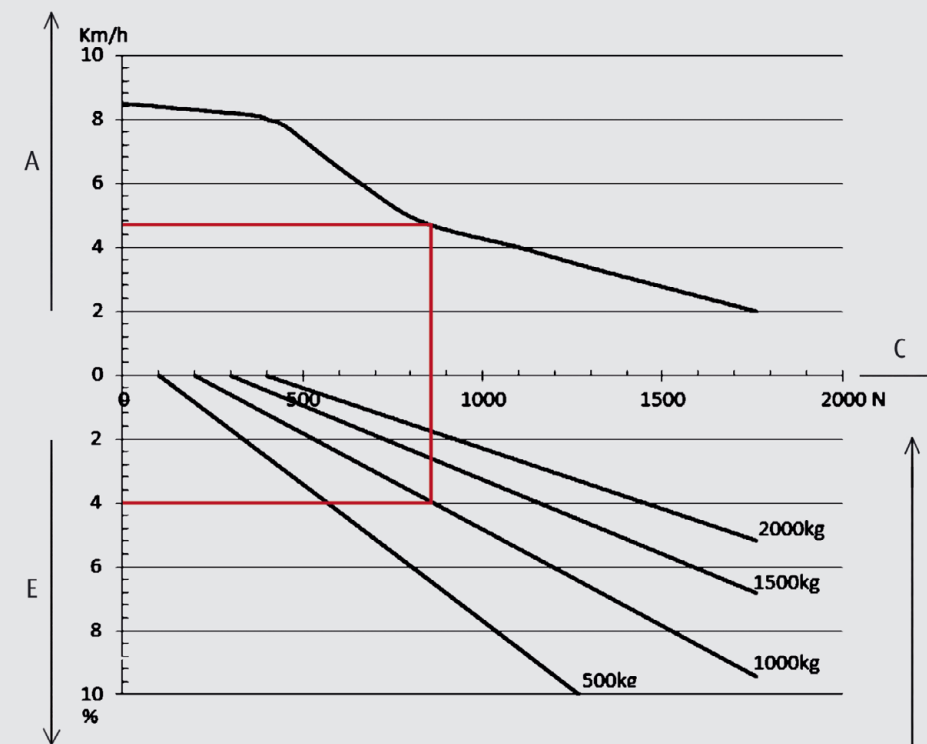
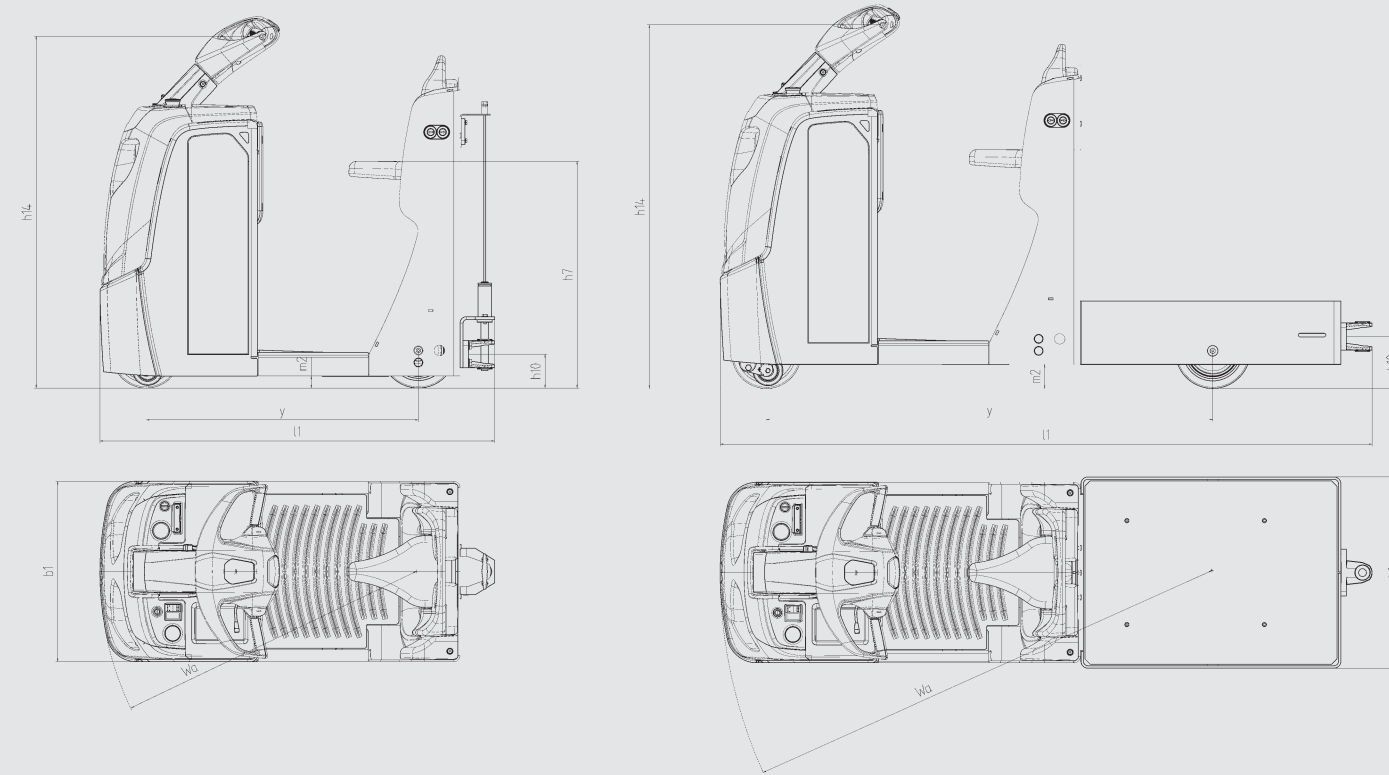

A	Speed [km/h]
C	Drawbar pull [N]
D	Trailer weight [kg]
E	Gradient [%]

The example shown above illustrates:

P20 drives up a 4% gradient (E) with a trailer weight of 1000 kg (D). 850 N drawbar pull (C) is required and maximum speed is 4.5 km/h (A). It is recommended that braked trailers are used for trailer loads exceeding 2.5 t and for all trailer loads where a gradient is involved.



По вопросам продаж и поддержки обращайтесь:

Архангельск (8182)63-90-72	Краснодар (861)203-40-90	Рязань (4912)46-61-64
Астана (7172)727-132	Красноярск (391)204-63-61	Самара (846)206-03-16
Белгород (4722)40-23-64	Курск (4712)77-13-04	Санкт-Петербург (812)309-46-40
Брянск (4832)59-03-52	Липецк (4742)52-20-81	Саратов (845)249-38-78
Владивосток (423)249-28-31	Магнитогорск (3519)55-03-13	Смоленск (4812)29-41-54
Волгоград (844)278-03-48	Москва (495)268-04-70	Сочи (862)225-72-31
Вологда (8172)26-41-59	Мурманск (8152)59-64-93	Ставрополь (8652)20-65-13
Воронеж (473)204-51-73	Набережные Челны (8552)20-53-41	Тверь (4822)63-31-35
Екатеринбург (343)384-55-89	Нижний Новгород (831)429-08-12	Томск (3822)98-41-53
Иваново (4932)77-34-06	Новокузнецк (3843)20-46-81	Тула (4872)74-02-29
Ижевск (3412)26-03-58	Новосибирск (383)227-86-73	Тюмень (3452)66-21-18
Казань (843)206-01-48	Орел (4862)44-53-42	Ульяновск (8422)24-23-59
Калининград (4012)72-03-81	Оренбург (3532)37-68-04	Уфа (347)229-48-12
Калуга (4842)92-23-67	Пенза (8412)22-31-16	Челябинск (351)202-03-61
Кемерово (3842)65-04-62	Пермь (342)205-81-47	Череповец (8202)49-02-64
Киров (8332)68-02-04	Ростов-на-Дону (863)308-18-15	Ярославль (4852)69-52-93

Единый адрес: edi@nt-rt.ru **Веб-сайт:** www.linde.nt-rt.ru