

По вопросам продаж и поддержки обращайтесь:

Архангельск (8182)63-90-72	Краснодар (861)203-40-90	Рязань (4912)46-61-64
Астана (7172)727-132	Красноярск (391)204-63-61	Самара (846)206-03-16
Белгород (4722)40-23-64	Курск (4712)77-13-04	Санкт-Петербург (812)309-46-40
Брянск (4832)59-03-52	Липецк (4742)52-20-81	Саратов (845)249-38-78
Владивосток (423)249-28-31	Магнитогорск (3519)55-03-13	Смоленск (4812)29-41-54
Волгоград (844)278-03-48	Москва (495)268-04-70	Сочи (862)225-72-31
Вологда (8172)26-41-59	Мурманск (8152)59-64-93	Ставрополь (8652)20-65-13
Воронеж (473)204-51-73	Набережные Челны (8552)20-53-41	Тверь (4822)63-31-35
Екатеринбург (343)384-55-89	Нижний Новгород (831)429-08-12	Томск (3822)98-41-53
Иваново (4932)77-34-06	Новокузнецк (3843)20-46-81	Тула (4872)74-02-29
Ижевск (3412)26-03-58	Новосибирск (383)227-86-73	Тюмень (3452)66-21-18
Казань (843)206-01-48	Орел (4862)44-53-42	Ульяновск (8422)24-23-59
Калининград (4012)72-03-81	Оренбург (3532)37-68-04	Уфа (347)229-48-12
Калуга (4842)92-23-67	Пенза (8412)22-31-16	Челябинск (351)202-03-61
Кемерово (3842)65-04-62	Пермь (342)205-81-47	Череповец (8202)49-02-64
Киров (8332)68-02-04	Ростов-на-Дону (863)308-18-15	Ярославль (4852)69-52-93

Единый адрес: edi@nt-rt.ru **Веб-сайт:** www.linde.nt-rt.ru

Взрывозащищенные ричтраки R 14-20 S Ex LINDE МН. Техническое описание



Electric Reach Trucks for potentially hazardous areas

Capacity 1400 – 2000 kg
R 14 Ex S – R 20 Ex S

SERIES 115-02

Explosion-Protected Trucks

The R 14 Ex S up to R 20 Ex S electric reach trucks for use in explosion-hazard areas are based on the standard truck model design-Series 115-02.

These specialised trucks also incorporate the high performance and unique features of the standard high volume models:

Exemplary ergonomics, advanced technology, high stability, excellent economy and extended working life.

The trucks comply with EG regulations for use in potentially explosive environments (EN 1755) and the ATEX version has been type-tested to Directive 94/4/EC by the „Institut National De L’environnement Industriel et des Risques“ (INERIS). **Type Examination Certificate: 07ATEX3001 X.**

Accordingly, these type-tested trucks are approved for use in potentially hazardous areas as follows:

- Zone 1 (2G), IIA or II B, temperature class to T4
- Zone 2 (3G), IIA or II B, temperature class to T4

Safety

AC drive motors, lift hydraulics and steering are guarded to comply with Ex-proof regulations.

The control units, gates and relays are protected by pressure-tight „d“ casings to ensure their safety in potentially hazardous atmospheres.

All motors, brakes, oil-valves and controls are temperature monitored.

The pressure-tight multifunction display provides the truck’s operating status.

Additionally, electrically conducting tyres and a non-sparking fork coating enhances the trucks safety levels for operation in potentially hazardous areas.

Linde Material Handling

Linde

Technical data

Additional data and models in standard data sheets of series 115-02, except N-versions

Characteristics	1.1	Manufacturer		LINDE	LINDE	LINDE	
	1.2	Model designation		R 14 Ex S	R 16 Ex S	R 20 Ex S	
	1.3	Power unit: battery, diesel, petrol, LP gas, mains power		Battery	Battery	Battery	
	1.4	Operation: manual, pedestrian, stand-on, seated, order picker		seated	seated	seated	
	1.5	Load capacity	Q (t)	1,4 ³⁾	1,6 ³⁾	2,0 ³⁾	
	1.6	Load centre	c (mm)	600/500	600/500	600/500	
	1.8	Axle centre to fork face	x (mm)	311	416	475	
	1.9	Wheelbase	y (mm)	1275	1385	1520	
	Weights	2.1	Service weight	kg	2940	2990	3310
2.3		Axle load without load, front (drive)/rear (load)	kg	1825/1115	1925/1065	2135/1165	
2.4		Axle load, fork outreached with load, front (drive)/rear (load)	kg	1825/1115	1925/1065	2135/1165	
2.5		Axle load, fork retracted with load, front (drive)/rear (load)	kg	1510/2830	1715/2875	1985/3325	
3.1		Tyres, front (drive)/rear (load) C = cushion rubber, P = polyurethane		Polyurethan	Polyurethan	Polyurethan	
Wheels and tyres	3.2	Tyre size, front (drive) wheel	mm	343 x 135	343 x 135	343 x 135	
	3.3	Tyre size, rear (load) wheel	mm	285 x 100	285 x 100	350 x 100	
	3.5	Wheels, number front (drive)/rear (load)		1x/2	1x/2	1x/2	
	3.6	Track width, front (drive)	b10 (mm)	0	0	0	
	3.7	Track width, rear (load)	b11 (mm)	1150	1150	1150	
	Dimensions	4.1	Mast/fork carriage tilt, forward/backward	a/b (°)	2/4	2/4	2/4
		4.2	Height of mast, lowered	h1 (mm)	2110	2110	2476
4.3		Free lift	h2 (mm)	1261	1261	1627	
4.4		Lift	h3 (mm)	4655 ¹⁾	4655 ¹⁾	4655 ¹⁾	
4.5		Height of mast, extended	h4 (mm)	5395	5395	5395	
4.7		Height of overhead guard (cabin)	h6 (mm)	2110	2110	2110	
4.8		Height of seat/stand-on platform	h7 (mm)	940/1030	940/1030	940/1030	
4.10		Height of reach legs	h8 (mm)	310	310	373	
4.19		Overall length	l1 (mm)	2384	2389	2461	
4.20		Length to fork face	l2 (mm)	1184	1189	1261 ⁶⁾	
4.21		Overall width	b1/b2 (mm)	1234/1250	1234/1250	1234/1250 ⁷⁾	
4.22		Fork dimensions	s/e/l (mm)	51 x 106 x 1150	51 x 106 x 1150	51 x 106 x 1150	
4.23		Fork carriage to DIN 15173, class/form A, B		2A	2A	2A	
4.24		Width of fork carriage		830	830	830	
4.25		Fork spread, minimum/maximum		296/690	316/710	316/710	
4.26		Width between reach legs		922	922	922	
4.28		Reach travel	b3 (mm)	496	606	695	
4.31		Ground clearance, mast	m1 (mm)	75	75	75	
4.32		Ground clearance, centre of wheelbase	m2 (mm)	75	75	75	
4.33		Aisle width with pallet 1000 x 1200 across forks	Ast (mm)	2709	2729	2821	
4.34		Aisle width with pallet 800 x 1200 along forks	Ast (mm)	2781	2785	2867	
4.35		Turning radius	Wa (mm)	1540	1640	1775	
4.37		Length of chassis	l7 (mm)	1638	1748	1911	
Performance	5.1	Travel speed, with/without load	km/h	12.5/12.5	12.5/12.5	12.5/12.5	
	5.2	Lifting speed, with/without load	m/s	0.34/0.6 ⁴⁾	0.34/0.6 ⁴⁾	0.3/0.48 ⁴⁾	
	5.3	Lowering speed, with/without load	m/s	0.55/0.45 ⁴⁾	0.55/0.45 ⁴⁾	0.55/0.4 ⁴⁾	
	5.4	Reach speed, with/without load	N	0.15/0.15 ⁴⁾	0.15/0.15 ⁴⁾	0.15/0.15 ⁴⁾	
	5.7	Climbing ability, with/without load, 30 minutes rating	%	4.3/7.8	4.5/7.8	3.7/6.7	
	5.8	Max. climbing ability, with/without load, 5 minutes rating	%	9.5/9.5	9.5/9.5	9.5/9.5	
	5.9	Acceleration time, with/without load	s	5.2/4.6	5.2/4.6	5.5/4.8	
	5.10	Service brake		hydraulic/electr.	hydraulic/electr.	hydraulic/electr.	
	Drive	6.1	Drive motor, 60 minutes rating	kW	6	6	6
		6.2	Lift motor, 15 % rating	kW	12	12	12
6.3		Battery according to IEC		254-2	254-2	254-2	
6.4		Battery voltage/rated capacity (5h)	V/Ah	48/420	48/420	48/560	
6.5		Battery weight (±5 %)	kg	731	731	922	
6.6		Power consumption according to VDI cycle	kW/h	⁸⁾	⁷⁾	⁷⁾	
Other	8.1	Type of drive control		electronic/stepless	electronic/stepless	electronic/stepless	
	8.2	Working pressure for attachments	bar	200	200	200	
	8.3	Oil flow for attachments	l/min	6.5	6.5	6.5	
	8.4	Noise level at operator's ear	dB (A)	63 ⁸⁾	63 ⁸⁾	64 ⁸⁾	
1) For all heights, see standard data sheets of series 2) Alternative batteries increase length to fork face and 90° stacking aisle widths 3) Capacity may be reduced for high lifts 4) Traction, lift, lower and reach speeds and weights may vary with alternative lift heights 5) Lift heights 6400 mm and above increase length widths by 27 mm on R20			6) Alternative widths over reach legs of 1400 mm 7) Refer to manufacturer for figures 8) Figure shown is without cab; 66 dB (A) when cab fitted 9) Figures shown in brackets are for intrusive stacking 10) Reduced speed and acceleration on request				

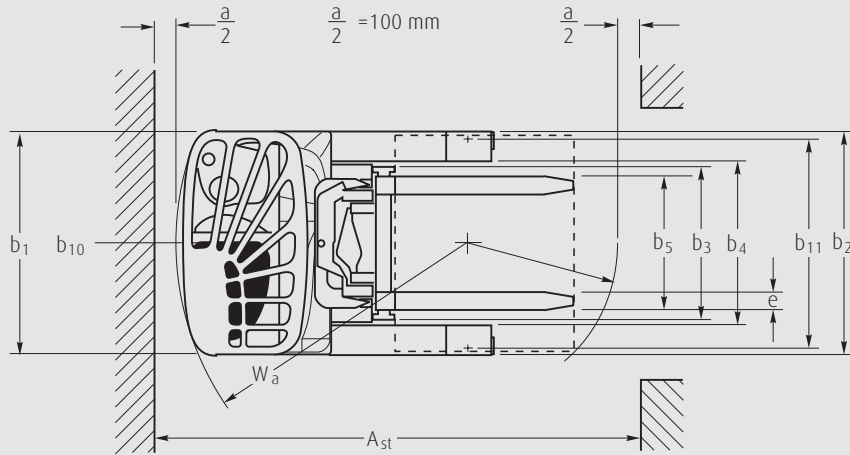
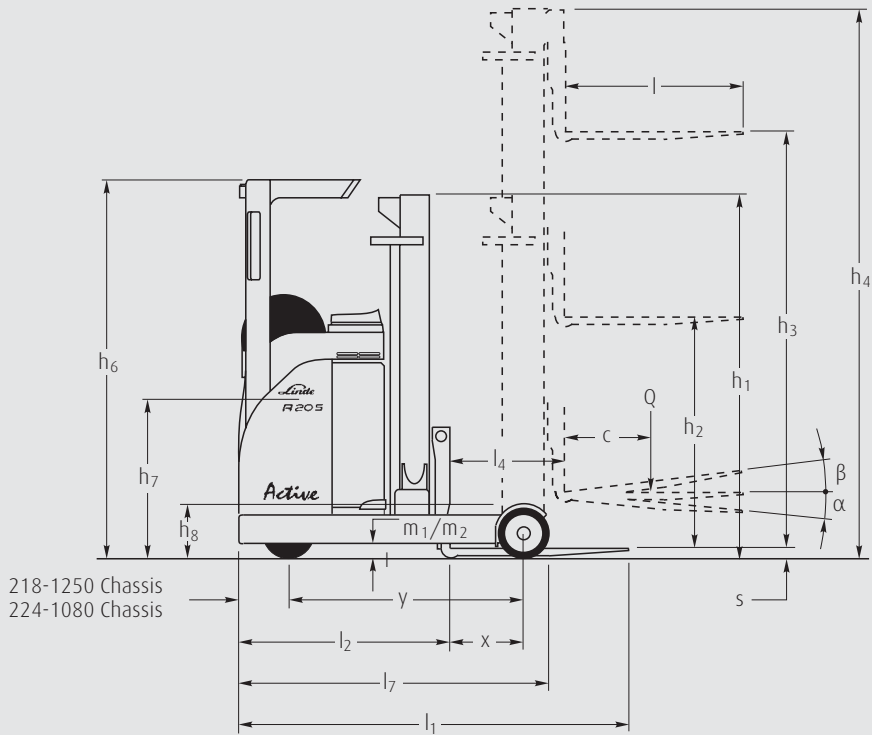

Lifting capacity diagrams in standard data sheets of series 115-02

Ex-components are protected to comply with applications and are certified to ATEX.

This ensures the highest safety level for the operator.

Electrical control elements are "inherently safe" through the use of low voltages.

The temperature monitoring of drive, steering and lift motors, brakes and control module provides additional safety. The trucks are also equipped with anti-spark, brass coated forks.

The multifunction display is provided in a pressure-tight casing and features the same overview of readouts like standard models.

According to ATEX guidelines, the battery coupling and plugs are especially developed by Linde MH and certified.

Special equipment is also adapted to the required ex-protection class. On the basis of the facts the truck represents a closed safety system.



Ex-protected drive/steering/lift motor and hydraulic tank



Pressure tight multifunction display



Ex-battery connection

Features

Linde clear-view mast

- Torsion resistant fixed triplex clear-view mast
- Tilting fork carriage
- Integral sideshift
- Hydraulic hose runs within mast sections



Stability

- Chassis designed and built for maximum strength
- Bottom part of frame made of cast steel to improve center of gravity, stability and residual capacity

Forks

- Brass coated to prevent sparking

Maneuverability

- Short wheelbase and compact chassis dimensions permit easy maneuvering

Linde Load Control

- Safe and seamless load handling with millimetre accuracy
- Effortless fingertip control of all mast functions
- Joystick controls integrated into the armrest

Linde twin drive pedal

- Seamless, rapid reversing without repositioning the feet
- Short pedal travel
- Fatigue-free working
- Increased throughput and performance



Linde operator compartment

- Ergonomically designed for efficient, fatigue-free working
- Spacious operator's compartment with generous floor plate area
- Cushioned comfort – mast and drive axle are isolated from the chassis and cab by a unique resilient suspension system that absorbs shock loadings

Batteries

- Optimum size of battery for every application: 280 Ah to 620 Ah depending on truck model
- Quick and easy battery change

Ex-battery

- Ex-tested battery cells, battery cover
- Specialised Ex-proof connection

Servicing

- Maintenance-free pressure tight AC traction and lift motors for use in Ex-areas
- Configurable Linde Digital Control System
- Controls and components tuned to the Ex-environment
- All points requiring servicing conveniently grouped
- Modern CAN bus architecture

Subject to modification in the interests of engineering progress. Illustrations and technical details non-binding for actual construction. All measurements subject to customary tolerances.

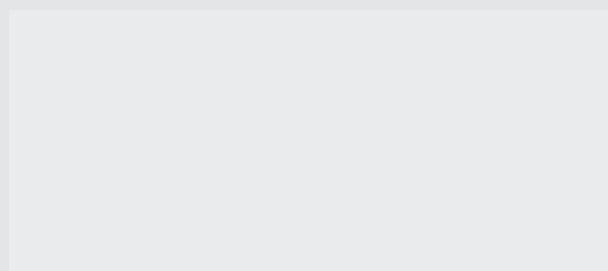

По вопросам продаж и поддержки обращайтесь:

Архангельск (8182)63-90-72	Краснодар (861)203-40-90	Рязань (4912)46-61-64
Астана (7172)727-132	Красноярск (391)204-63-61	Самара (846)206-03-16
Белгород (4722)40-23-64	Курск (4712)77-13-04	Санкт-Петербург (812)309-46-40
Брянск (4832)59-03-52	Липецк (4742)52-20-81	Саратов (845)249-38-78
Владивосток (423)249-28-31	Магнитогорск (3519)55-03-13	Смоленск (4812)29-41-54
Волгоград (844)278-03-48	Москва (495)268-04-70	Сочи (862)225-72-31
Вологда (8172)26-41-59	Мурманск (8152)59-64-93	Ставрополь (8652)20-65-13
Воронеж (473)204-51-73	Набережные Челны (8552)20-53-41	Тверь (4822)63-31-35
Екатеринбург (343)384-55-89	Нижний Новгород (831)429-08-12	Томск (3822)98-41-53
Иваново (4932)77-34-06	Новокузнецк (3843)20-46-81	Тула (4872)74-02-29
Ижевск (3412)26-03-58	Новосибирск (383)227-86-73	Тюмень (3452)66-21-18
Казань (843)206-01-48	Орел (4862)44-53-42	Ульяновск (8422)24-23-59
Калининград (4012)72-03-81	Оренбург (3532)37-68-04	Уфа (347)229-48-12
Калуга (4842)92-23-67	Пенза (8412)22-31-16	Челябинск (351)202-03-61
Кемерово (3842)65-04-62	Пермь (342)205-81-47	Череповец (8202)49-02-64
Киров (8332)68-02-04	Ростов-на-Дону (863)308-18-15	Ярославль (4852)69-52-93

Единый адрес: edi@nt-rt.ru **Веб-сайт:** www.linde.nt-rt.ru